

ETAP Motor Starting Analysis

The ETAP V&V process for the Motor Starting program has over 1600 test case scenarios that are run before each ETAP release. The following cases are excerpts from the Motor Starting V&V documentation.

Motor Starting Comparison Case # 1

Comparison of ETAP Motor Starting with Torque Control Against Hand Calculated Results

Excerpts from Validation Cases and Comparison Results (TCS-MS-149)

Highlights:

- Comparison of ETAP Motor acceleration results against Hand Calculations.
- Torque Control Solid-State Motor Starting Device is used to start the motor.
- Single1, Single2, Double1 and Double2 CKT models are used in the hand calculation.
- Motor is rated at 500 HP at 4 kV, RPM = 1800, %PF = 89.85 and %Eff = 94.14.
- The compared results include the motor Power Output, Reactive Power Input, Motor Current, Terminal Voltage and Power Factor at different Slip values.
- Hand Calculations were accomplished using Mathcad. The equations for motor modeling were obtained from different sources.
- The same system was used for the different motor CKT models.

System Description:

This is a 3-Phase system that consists of three induction motors. One of the induction motors at the 0.480 kV bus is being started at $t = 0$ sec. The CKT model parameters are as shown on the Model page. The motor being started is **Mtr3**.

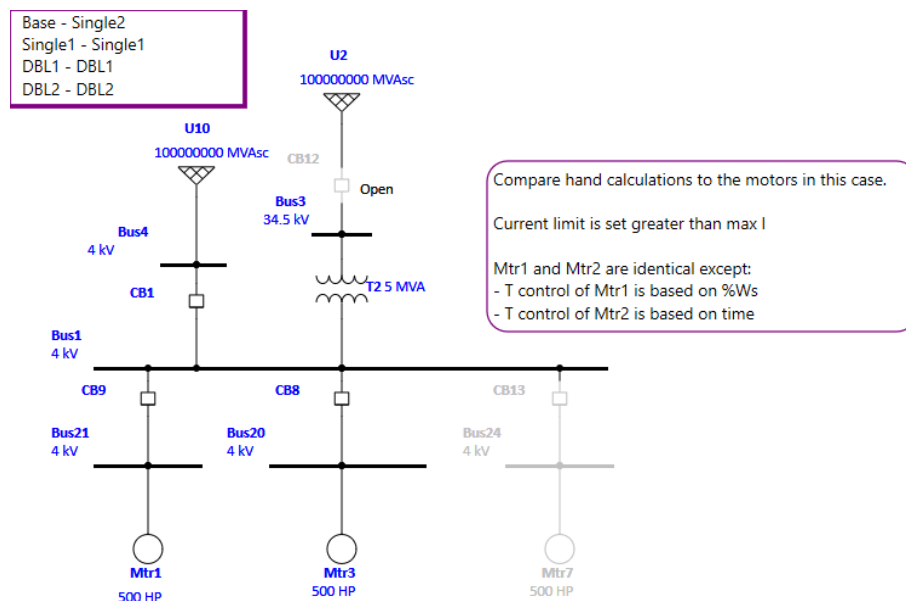

The following is a sample of the hand calculations that were performed for each motor model.

Hand Calc's

Single2 Model:

$$\text{MotorkV} := 4$$

$$\text{MotorMVA} := 0.4408$$

$$Z_B := \frac{\text{MotorkV}^2}{\text{MotorMVA}} \quad Z_B = 36.29764 \quad R_{2LR} := 0.0123 \cdot Z_B \quad R_{2LR} = 0.44646$$

$$R_1 := 0.0383 \cdot Z_B \quad R_{2FL} := 0.0152 \cdot Z_B \quad R_{2FL} = 0.55172$$

$$X_1 := 0.1029 \cdot Z_B \quad X_{2LR} := 0.093 \cdot Z_B \quad X_{2LR} = 3.37568$$

$$X_m := 3.652 \cdot Z_B \quad X_{2FL} := 0.1167 \cdot Z_B \quad X_{2FL} = 4.23593$$

Find rated slip using trial and error until current (I1) is satisfied:

$$s_{\text{rated}} := 0.0155022$$

$$R_2 := (R_{2FL} - R_{2LR}) \cdot (1 - s_{\text{rated}}) + R_{2LR} \quad R_2 = 0.55009$$

$$X_2 := (X_{2FL} - X_{2LR}) \cdot (1 - s_{\text{rated}}) + X_{2LR} \quad X_2 = 4.2226$$

$$Z_{\text{eq}} := R_1 + X_1 i + \left(\frac{1}{X_m i} + \frac{1}{\frac{R_2}{s_{\text{rated}}} + X_2 \cdot i} \right)^{-1} \quad Z_{\text{eq}} = 32.61631 + 15.92816i$$

$$I_1 := \frac{\frac{\text{MotorkV} \cdot 1000}{\sqrt{3}}}{|Z_{\text{eq}}|} \quad I_1 = 63.62373$$

Calculate the relationship (K) between Pout and Pag to compensate for rotational losses

$$\text{PF} := \cos(\arg(Z_{\text{eq}})) \quad \text{PF} = 0.89858$$

$$P_{\text{ag}} := \sqrt{3} \cdot \text{MotorkV} \cdot I_1 \cdot \text{PF} - \frac{(3I_1^2 \cdot R_1)}{1000} \quad P_{\text{ag}} = 379.20791$$

$$P_{\text{conv}} := (1 - s_{\text{rated}}) \cdot P_{\text{ag}} \quad P_{\text{conv}} = 373.32935$$

$$P_{\text{out}_{\text{rated}}} := 500 \cdot 0.7457 \quad P_{\text{out}_{\text{rated}}} = 372.85$$

$$K_{\text{ga}} := \frac{P_{\text{ag}}}{P_{\text{out}_{\text{rated}}}} \quad K_{\text{ga}} = 1.01705$$

Comparison of Results:

The following tables of comparisons illustrate the comparisons made between ETAP Motor Starting and the Mathcad hand calculations. Please note that in all cases, the % difference for all the compared parameters is less than 0.4%.

Table 1: Comparisons of ETAP Motor Starting Results with a Torque Control Starting Device against Hand Calculations at various Motor Slip points for different circuit (CKT) model types.

Single2 Model:

s (pu)	t (s)	Benchmark		ETAP		% Diff	
		P (kW)	Q (kvar)	P (kW)	Q (kvar)	P (%)	Q (%)
0.899978	0.876	7.45864	1558.67	7.45314	1558.65	0.073	0.001
0.699989	2.362	32.1615	1605.76	32.1431	1605.82	0.057	0.004
0.689957	2.416	35.0731	1634.12	35.1323	1635.86	0.169	0.106
0.670009	2.517	41.2157	1684.88	41.2054	1684.95	0.025	0.004
0.62994	2.722	47.4067	1647.67	47.3345	1646.91	0.152	0.046
0.55019	3.237	58.7214	1542.35	58.7005	1542.51	0.036	0.010
0.250022	4.417	332.613	1749.12	331.954	1749.59	0.198	0.027
0.013967	10	336.174	179.364	336.174	179.312	0.000	0.029

Double1 Model:

s (pu)	t (s)	Benchmark		ETAP		% Diff	
		P (kW)	Q (kvar)	P (kW)	Q (kvar)	P (%)	Q (%)
0.900043	1.369	5.59035	2332.06	5.59005	2332.27	0.005	0.009
0.749985	2.831	17.7119	2400.7	17.7108	2400.89	0.006	0.008
0.739948	2.911	18.7474	2405.82	18.7435	2405.85	0.021	0.001
0.720057	3.072	20.8734	2414.29	20.8744	2414.63	0.005	0.014
0.690032	3.331	23.6091	2389.87	23.5611	2387.99	0.204	0.079
0.619981	4.126	29.7549	2299.64	29.7468	2300.02	0.027	0.017
0.499961	5.21	73.4686	2829.61	73.4742	2829.85	0.008	0.008
0.249992	7.744	215.571	2794.31	215.583	2794.55	0.006	0.009
0.003514	10	344.09	168.2	344.09	168.313	0.000	0.067

Double2 Model:

s (pu)	t (s)	Benchmark		ETAP		% Diff	
		P (kW)	Q (kvar)	P (kW)	Q (kvar)	P (%)	Q (%)
0.89999	1.364	5.5933	1072.45	5.59323	1072.53	0.001	0.007
0.749945	2.82	17.716	1136.02	17.7141	1136.05	0.011	0.003
0.739993	2.899	18.7427	1141.19	18.738	1141.14	0.025	0.004
0.720021	3.06	20.8773	1151.11	20.8773	1151.22	0.000	0.010
0.689995	3.318	23.6125	1149.11	23.5645	1148.16	0.203	0.083
0.620011	4.109	29.7526	1132.15	29.7447	1132.28	0.027	0.011
0.499838	4.515	408.839	3357.97	410.165	3356.05	0.324	0.057
0.249964	4.677	578.276	2995.05	579.058	2993.37	0.135	0.056
0.003522	10	344.084	164.803	344.084	164.836	0.000	0.020

Single1 Model:

s (pu)	t (s)	Benchmark		ETAP		% Diff	
		P (kW)	Q (kvar)	P (kW)	Q (kvar)	P (%)	Q (%)
0.900008	0.835	7.4564	1473.97	7.45092	1473.94	0.074	0.002
0.699987	2.252	32.1621	1555.32	32.1433	1555.34	0.058	0.001
0.690051	2.303	35.0452	1585.36	35.1006	1587.01	0.158	0.104
0.66996	2.4	41.2247	1640.66	41.211	1640.66	0.033	0.000
0.629982	2.595	47.4	1610.61	47.3275	1609.82	0.153	0.049
0.550047	3.086	58.7177	1518.09	58.6964	1518.23	0.036	0.009
0.249183	3.67	1209.53	3005.72	1208.18	3007.83	0.112	0.070
0.01304	10	336.877	174.338	336.872	174.444	0.001	0.061

Table 2: Comparison of ETAP Motor Starting Results with a Torque Control Starting Device against Hand Calculations at various Motor Slip points for Characteristic Model.

Characteristic Model:

s (pu)	t (s)	Benchmark		
		V (%)	I (%)	Q (kvar)
0.900083	0.838	72.2158	359.635	1557.5
0.689961	2.354	76.409	373.631	1609.15
0.67999	2.407	77.88	380.351	1636.17
0.599963	2.822	78.7452	380.733	1633.47
0.500036	3.645	72.5149	344.736	1480.61
0.013515	10	99.9902	144.196	359.303

s (pu)	t (s)	ETAP		
		V (%)	I (%)	Q (kvar)
0.900083	0.838	72.2168	359.677	1557.59
0.689961	2.354	76.4076	373.638	1609.08
0.67999	2.407	77.9644	380.778	1637.82
0.599963	2.822	78.7251	380.67	1633.12
0.500036	3.645	72.5216	344.762	1480.61
0.013515	10	99.9971	144.201	359.174

s (pu)	t (s)	% Diff		
		V (%)	I (%)	Q (%)
0.900083	0.838	0.001	0.012	0.006
0.689961	2.354	0.002	0.002	0.004
0.67999	2.407	0.108	0.112	0.101
0.599963	2.822	0.026	0.017	0.021
0.500036	3.645	0.009	0.008	0.000
0.013515	10	0.007	0.003	0.036