

# Running a Load Flow Analysis

The purpose of this tutorial is to introduce the Load Flow Analysis module, and provide instructions on how to run a load flow study. In addition, an example of how to regulate bus voltage using transformer LTCs and how ETAP flags overload conditions will be given. Furthermore, there will be a brief look at the Load Flow Result Analyzer. For this tutorial you should select “Example Project (ANSI)” option when starting ETAP Demo.

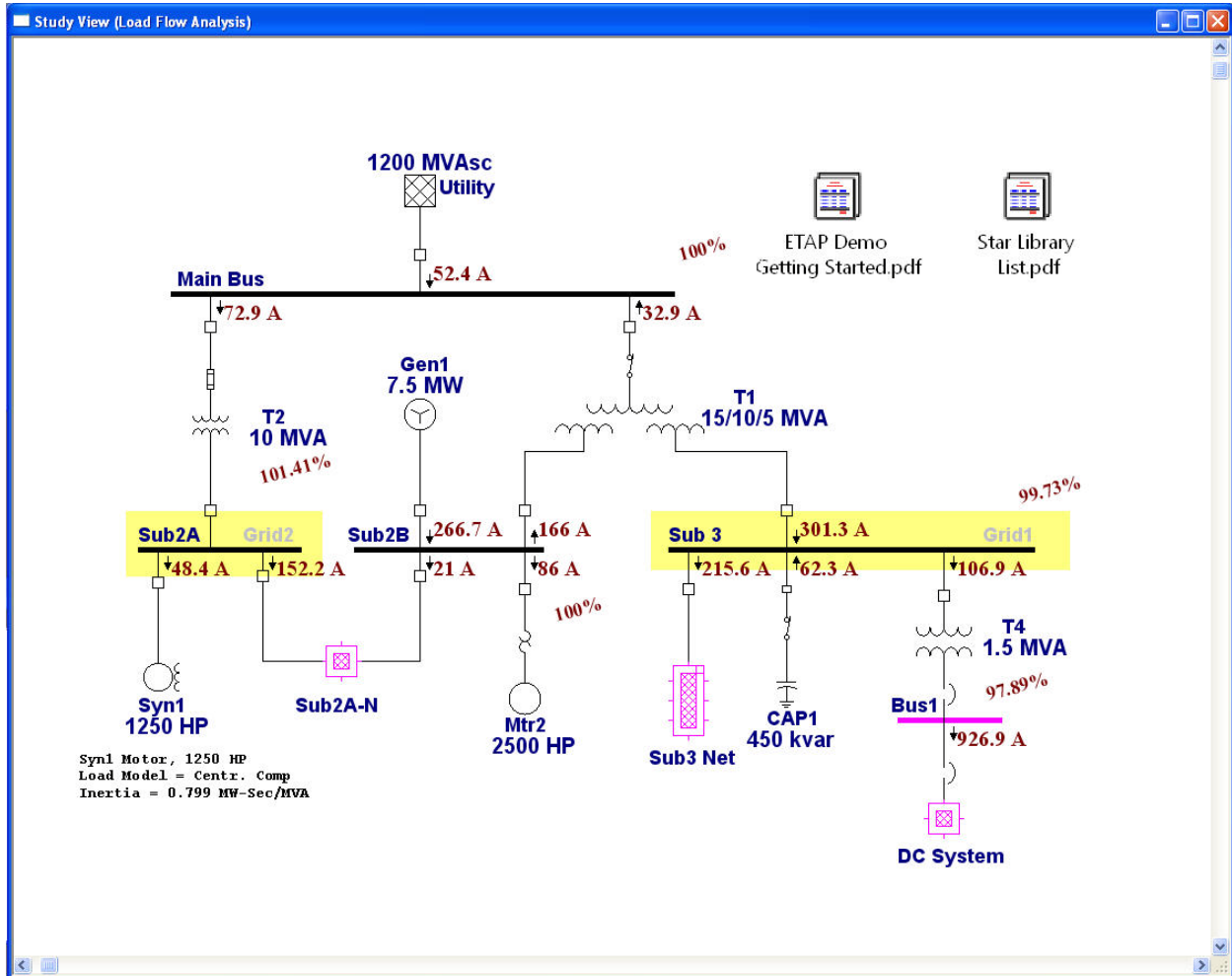

Example – ANSI after running load flow analysis

## Running Load Flow Analysis

Click the Load Flow Analysis button on the Mode toolbar to switch to Load Flow Analysis mode.



Running a Load Flow Analysis will generate an output report. In the Study Case toolbar, you can select the name of an existing output report to overwrite, or “Prompt.” If “Prompt” is selected, then prior to running the Load Flow Analysis you will be prompted to enter a new report name.



You can customize your study by changing the options in the Load Flow Study Case editor. For example, different methods with maximum number of iterations and precision can be specified; loading and generation categories can be individually selected; load diversity factors can be applied; and finally adjustments can be selected for different elements, e.g. transformer, reactor, overload heater, cable, transmission line, and more.

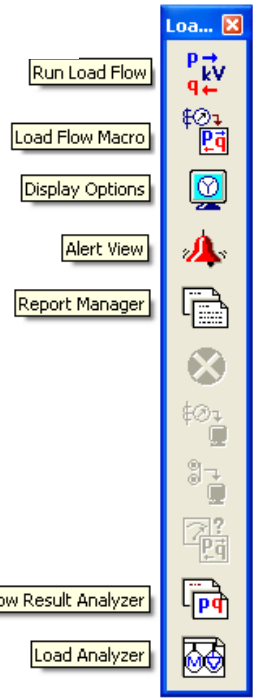

### Viewing the Results

To run the load flow study, click on the Run Load Flow button located in the Load Flow toolbar. After running the Load Flow Analysis, the results will be displayed on the one-line, as shown below:

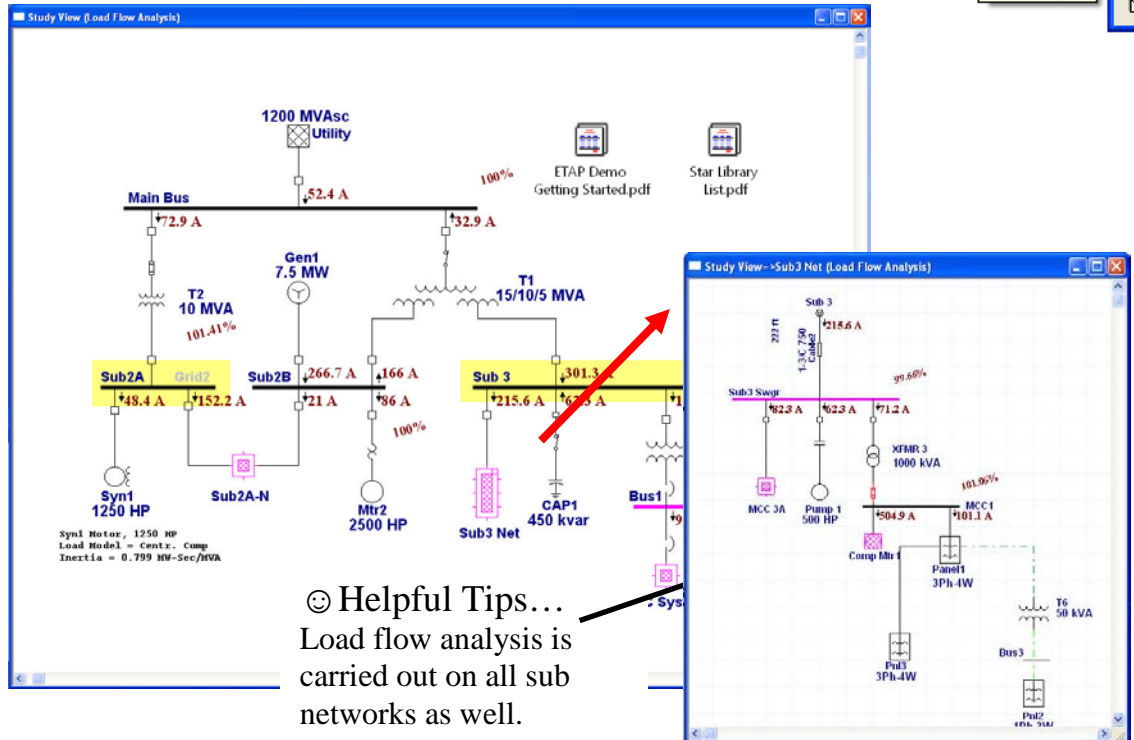

☺ Helpful Tips... Load flow analysis is carried out on all sub networks as well.

The results shown on the one-line, and the format they are displayed in can be changed in the Display Options, which can be accessed from the Load Flow toolbar.

To view any overload problems, simply click the Alert View button in the Load Flow toolbar. This will open a window containing a list of undersized equipment. Please note that the alert view button is disabled in the ETAP Demo.

**Load Flow Analysis Alert View - Output Report: LFreport**

Study Case: LF 100A      Data Revision: Base  
 Configuration: Normal      Date: 09-16-2004

Critical						
Device...	Type	Rating	Calcula...	% Value	Condition	Phase ...
CB31	LV CB	800 Amp	926.392	115.8	OverLoad	3-Phase
CB32	LV CB	175 Amp	306.42	175.1	OverLoad	3-Phase
Fuse3	Fuse	390 Amp	1239.913	317.9	OverLoad	3-Phase
Gen1	Generator	0 Mvar	0		UnderEx...	3-Phase
XFMR 3	Transfor...	1 MVA	1.028	102.8	OverLoad	3-Phase

Marginal						
Device...	Type	Rating	Calcula...	% Value	Condition	Phase ...
Bus1	Bus	0.48 kV	0.47	97.9	UnderV...	3-Phase
Bus2	Bus	0.48 kV	0.465	96.8	UnderV...	3-Phase
Fuse2	Fuse	125 Amp	119.932	95.9	OverLoad	3-Phase
Sub3 Swgr	Bus	225 Amp	208.301	92.6	OverLoad	3-Phase

**Display Options - Load Flow**

Results    AC    AC-DC    Colors

Show Units  
 Check-ALL

**Voltage**      **Power Flows**

%       kVA

Bus Mag.       kW + j kvar  
 Bus Angle       kVA       % PF  
 Load Term. Mag.       Amp

**Load Term. Base kV**      **Flow Results**

Load Rated kV       Branch  
 Bus Nom. kV       Source  
 Bus Angle       Load  
 Load FDR       Composite Motor  
 Load FDR       Composite Network

**Panel / UPS Systems**      **Branch Losses**

Results       kW + j kvar

Average Values      **Meters**  
 All Phases       Ammeter  
 Voltmeter  
 Multi-Meter

Help    OK    Cancel

Output reports provide a way to view a more detailed and organized representation of the results. Click on Report Manager in the Load Flow toolbar, and go to the Result page and select Load Flow Report. As you can see we offer different file formats for the output report.

**Load Flow Report Manager**

Complete    Input    **Result**    Summary

Load Flow Report       Viewer  
 Panel Report       PDF  
 UPS Report       MS Word  
                           Rich Text Format  
                           MS Excel  
 Set As Default

Output Report Name: LFreport

Path: C:\ETAP 555 Demo\Example\ANSI

Help    OK    Cancel

---

**ETAP Report - LFreport / Load Flow Report**

Project: Example      ETAP      Page: 1  
 Location: Irvine, California      5.5.5C      Date: 11-10-2006  
 Contract: OTI-12345678      SN: ETAP-OTI  
 Engineer: Operation Technology, Inc.      Study Case: LF 100A      Revision: Base  
 Filename: EXAMPLE      Config.: Normal

This info is printed on every output report, 1st remark line. (120 characters)  
 Second line of remarks for "LF 100A" study case.

**LOAD FLOW REPORT**

Bus ID	Voltage			Generation		Load		Load Flow			XFMR % Tap	
	kV	% Mag.	Ang.	MW	Mvar	MW	Mvar	ID	MW	Mvar		Amp
Bus1	0.480	97.891	-1.9	0	0	0	0	Bus2	0.654	0.375	926.9	86.7
								Sub 3	-0.654	-0.375	926.9	86.7
Bus2	0.480	96.775	-2.0	0	0	0.647	0.370	Bus1	-0.647	-0.370	926.9	86.8
LVBus	0.480	97.976	-3.0	0	0	0.554	0.174	Sub3 Swgr	-0.554	-0.174	712.9	95.4
*Main Bus	34.500	100.000	0.0	2.208	2.216	0	0	Sub2A	4.065	1.570	72.9	93.3
								Sub2B	-1.856	0.646	32.9	-94.4
								*Sub 3				
MCC1	0.480	101.063	-2.5	0	0	0.487	0.137	Sub3 Swgr	-0.487	-0.137	601.9	96.3
Sub2A	13.800	101.414	-1.5	0	0	0.998	-0.616	Main Bus	-4.059	-1.444	177.8	94.2
								Sub22	3.062	2.060	152.2	83.0
*Sub2B	13.800	100.000	1.1	6.300	0.971	1.908	0.763	Sub23	0.424	0.266	21.0	84.7
								Sub 3	3.968	-0.059	166.0	-100.0
								*Main Bus				
Sub 3	4.160	99.731	-0.6	0	0	0.000	-0.448	Sub3 Swgr	1.451	0.541	215.6	93.7

## Using the results

Looking at the results on the one-line, note that the operating voltage of Bus1 is 97.89%. This caused the bus to be flagged as marginally under voltage in the Alert View window. The criteria for which a condition is flagged can be changed in the Load Flow Study Case editor. We will now use the bus voltage regulation feature of the Transformer Editor to improve our Load Flow results.

ETAP allows Auto LTC settings to be applied to regulate buses that are directly or indirectly connected to a transformer. For example, we can use transformer T4 to regulate Bus1 at 100% of nominal voltage. Open the editor of T4 by double clicking on its graphic on the one-line. On the Tap page, enable (check) the Auto LTC box on the primary winding.

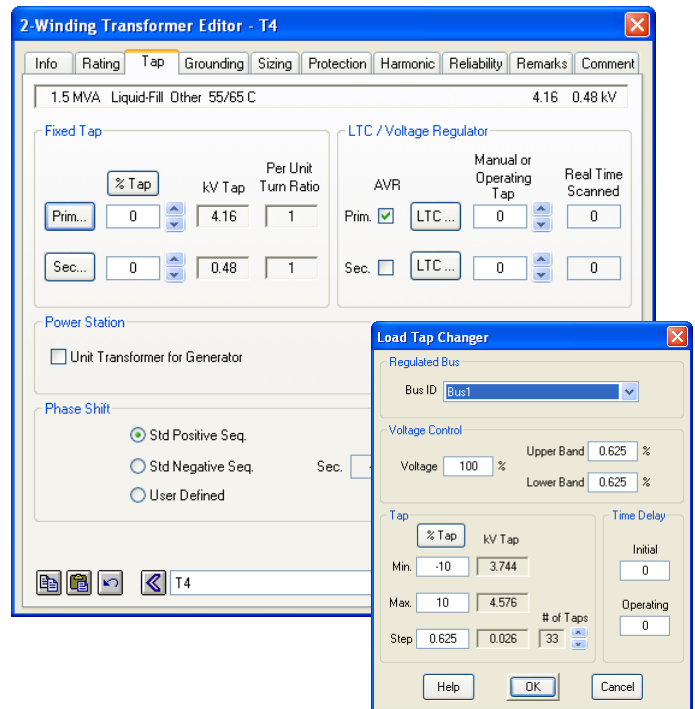

Open the LTC settings window by clicking on the LTC box and change the Regulated Bus ID to Bus1. Click OK for both the LTC window and the Transformer Editor window.

Run the Load Flow study again, with attention paid to the operating voltage of Bus1. Notice that the operating voltage of Bus1 is now within a tap step of the desired 100% regulation value. This is just one example of the many features of the ETAP Load Flow module.

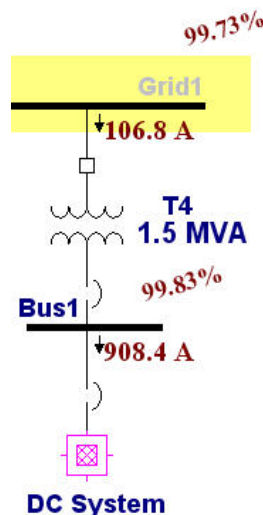

## Analyzing the Results

ID	Rating	Rated kV	kvar	kW	Amp	% PF	% Loading	Vterminal
CAP1	-450 kvar	4.16	-448	0	62.29	0	99.7	99.73
Load1	280 kVA	0.48	121	238	328.9	89.16	97.5	97.52
LTG Load	100 kVA	0.48	0	102	121.6	100	101	101.06
LUMP1	220 kVA	0.46	110	194	273.7	87	99.1	102.24
LUMP2	3500 kVA	3.3	1889	3048	609	85	99.5	103.01
LUMP5	500 kVA	3.45	263	424	83.8	85	100.2	99.61
MOV1	14.743 HP	0.46	0	0	0	0		102.24
Mtr2	2500 HP	13.2	762	1902	85.97	92.83	95.9	104.26
Mtr3	75 HP	0.46	26.927	60.474	78.79	91.35	94.8	105.46
Mtr4	125 HP	0.46	44.397	101	131.1	91.51	94.8	105.46
Mtr5	50 HP	0.46	19.389	40.962	53.95	90.39	94.9	105.43
Mtr6	120 HP	0.46	44.979	97.606	127.9	90.82	189.7	105.46
Pump 1	500 HP	4	184	407	62.31	91.09	96.6	103.55
Syn1	1250 HP	13.2	-617	995	48.37	-85	94.5	105.83
Syn2	150 HP	0.46	-58.505	121	165.5	-90	98.2	101.8

**Load Flow Result Analyzer**

- ☞ After running the Load Flow study, you can analyze the output data for different elements in a very compact and summarized way by using the Load Flow Results Analyzer. To do so, click on the Load Flow Result Analyzer button in the Load Flow toolbar.
- ☞ Select the different reports that you want to consider from the Study Reports field. If you want to compare output reports from other projects along with the current project, you can select All Project in Active Directory from the Project Report field. The other projects must be in the same directory as your current project.
- ☞ Select the report type from the Report Type field. The example above shows results for Loads. After selecting Loads, select the Load Types and Load Info to display. Select the units to display the results in, and the different fields that you want to display. In addition, you can create your own alerts and enable them from the Alert field.
- ☞ The commercial and nuclear versions of ETAP allow you to export the filtered results from the Load Flow Result Analyzer to an Excel spreadsheet.