

Short-Circuit ANSI & IEC

Instant Results, Comprehensive, Graphical Summary

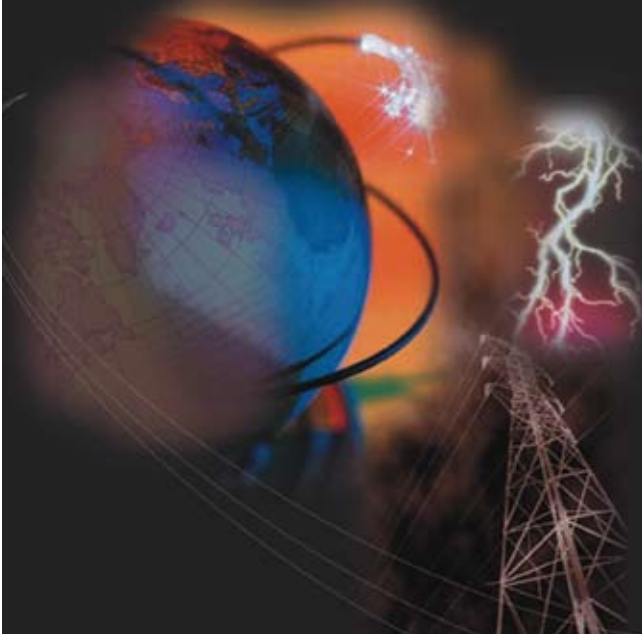

ANSI / IEEE Standards C37 & UL 489

IEC Standards 60909 & 61363

**Automatic Device Evaluation for
3-Phase, 1-Phase, & Panel Systems**

Load Terminal Short Circuit Calculation

Display Critical & Marginal Alerts

**Integrates with Star Protective Device
Coordination**

Seamless Transition to Arc Flash

As Easy as **1, 2, 3**

Save hours of tedious hand calculations and take the guesswork out of short circuit studies by automating the process with multiple calculation and result analysis tools within ETAP.

The Short-Circuit module makes it easy to go from selecting elements from the comprehensive libraries of short circuit current ratings to performing dozens of different types of short circuit analysis with the purpose of finding the worst-case device duty. Built-in intelligence allows it to automatically apply all ANSI / IEEE or IEC factors and ratios required for high- and low-voltage device duty evaluation. Determine fault currents and automatically compare these values against manufacturer short circuit current ratings. Overstressed device alarms are automatically displayed on the one-line diagram and reports.

OTI closely monitors industry standards and OEM data to ensure ETAP is always up-to-date. The Short-Circuit module seamlessly integrates with device coordination and performs arc flash hazard calculations.

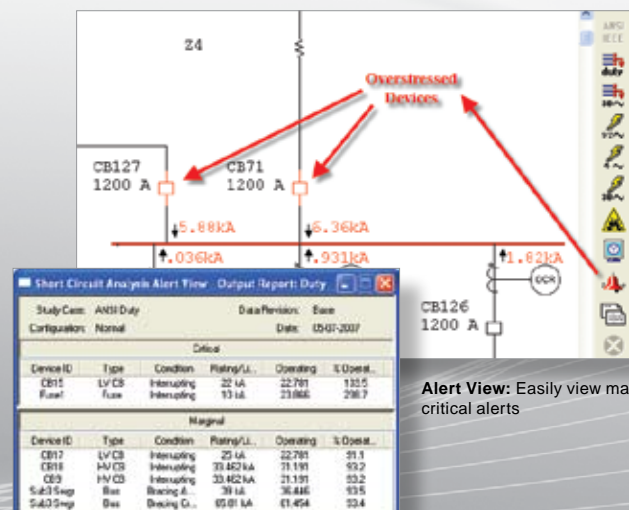

Alert View: Easily view marginal and critical alerts

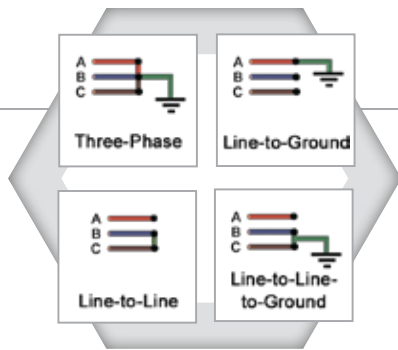

Device Duty Calculation & Evaluation for Single & Multiple-Phase Systems, Panel, & UPS

ANSI and IEC standards are used for calculating short circuit current for parts of the network below main panels, subpanels, UPS, and phase adapters. Device duty calculation compares the calculated fault current from these networks for evaluation of protective devices and automatically generates critical and marginal alerts based on user-defined alarm limits.

Capabilities

- Automatic 3-phase device evaluation
- Device evaluation based on total or maximum through fault current
- Automatically adjust conductor resistance & length (both lines & cables)
- Global or individual device impedance tolerance adjustments for maximum & minimum fault currents
- Include / exclude fault impedance modeling for unbalanced faults
- Include / exclude shunt admittance for branches & capacitive loads (unbalanced faults)
- Graphical or tabular bus fault selections
- Automatically determine fault currents at motor terminals without the need to add additional buses
- Phase-shifting transformers
- Grounding models for generators, transformers, motors, & other loads
- Motor contribution based on loading category, demand factor, or both
- Extract manufacturer published data from the libraries for thousands of devices

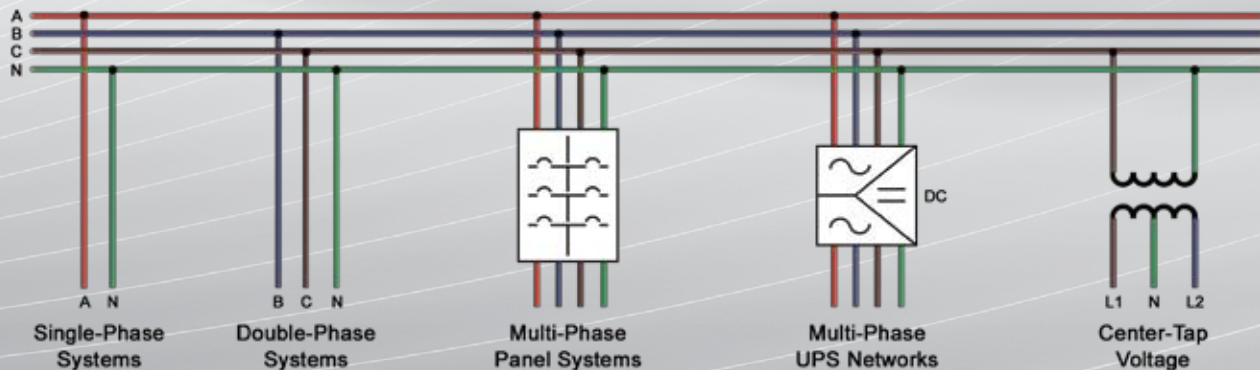
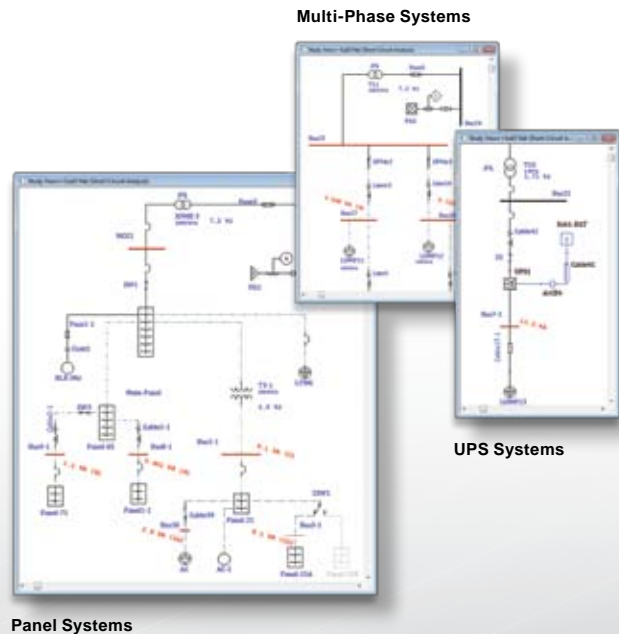

ANSI / IEEE Standards



Features

- 1-phase & panel systems device evaluation
- Determine maximum & minimum short circuit fault currents
- Calculate ½ cycle, 1.5–4, & 30 cycle balanced & unbalanced faults (3-phase, L-G, L-L, L-L-G)
- Check momentary & interrupting device capabilities
- Check closing & latching capabilities
- Evaluate symmetrical or total rated circuit breakers
- Special handling of generator circuit breakers for system & generator faults
- Interrupting duty as a function breaker contact parting time
- Standard & user-definable contact parting time
- Automatically includes No AC Decay (NACD) ratio
- User options for automatic adjustment of HVCB rating

Standards

- IEEE C37.04 Standard Rating Structure for AC High-Voltage Circuit Breakers Rated on a Symmetrical Current including Supplements: IEEE C37.04f, IEEE C37.04g, IEEE C37.04h, IEEE C37.04i
- IEEE C37.010 Standard Application Guide for AC High-Voltage Circuit Breakers Rated on a Symmetrical Current
- IEEE C37.010b Standard and Emergency Load Current-Carrying Capability
- IEEE C37.010e Supplement to IEEE C37.010
- IEEE C37.13 Standard for Low-Voltage AC Power Circuit Breakers Used in Enclosures
- IEEE C37.013 Standard for AC High-Voltage Generator Circuit Breakers Rated on a Symmetrical Current Basis
- IEEE C37.20.1 Standard for Metal Enclosed Low-Voltage Power Circuit Breaker Switchgear
- IEEE 399 Power System Analysis – the Brown Book
- IEEE 141 Electric Power Distribution for Industrial Plants – the Red Book
- IEEE 242 IEEE Recommended Practice for Protection and Coordination of Industrial and Commercial Power Systems – the Buff Book
- UL 489_9 Standard for Safety for Molded-Case Circuit Breakers, Molded-Case Switches, and Circuit Breaker Enclosures

Reporting (ANSI & IEC)

- Load terminal fault current reporting
- Automatically flag marginal & critical overstressed devices
- Individual fault current contributions for I_{sym} , I_a , & $3I_0$
- Phase & sequence voltage profiles (V_a , V_b , V_c , V_1 , V_2 , & V_0)
- Phase & sequence current profiles (I_a , I_b , I_c , I_1 , I_2 , & I_0)
- Phase & sequence impedances
- Alert view to display critical & marginal limit violations
- Export one-lines with short circuit results to third party CAD applications
- Input data, detailed individual & total short circuit contributions, & summaries
- Enhanced state-of-the-art graphic display of results for balanced & unbalanced faults
- Export output reports to your favorite word processor or spreadsheet
- Full color customizable Crystal Report® viewers

Load Terminal Fault Short-Circuit Current - 1/2 Cycle

Bus ID	ID	Load Type	KV	HP&M	KVA	Feeder Z (ohm)		1/2 Cycle Short-Circuit Current EA Symmetrical		
						Hotter & Cable R.	Cable X	System	Load	Total
Bus21A	Mr1	Inf. Motor	0.380	100.00	118.05	0.01658	0.00987	7.88	0.957	8.781
LVBus	Syn2	Syn. Motor	0.460	150.00	134.22	0.00944	0.00336	11.44	0.892	12.286
LVBus	Load1	Static Load	0.480	200.41	200.41	0.00261	0.00325	13.10	0.000	13.097
LVBus	CAP2	Capacitor	0.480	20.00	20.00	0.00102	0.00041	15.33	0.000	15.327
LVBus	MOV1	MOV	0.460	15.00	14.74	0.15087	0.02270	1.80	0.000	1.797
MCC1	Mr6	Inf. Motor	0.460	120.00	53.74	0.00000	0.00000	17.49	0.354	17.843
MCC1	Mr4	Inf. Motor	0.460	125.00	110.12	0.00000	0.00000	17.11	0.731	17.843
MCC1	Mr3	Inf. Motor	0.460	75.00	66.20	0.00000	0.00000	17.41	0.437	17.843

Reporting: Load terminal fault current reporting

IEC Standards



Features

- 1-pole / 2-pole short circuit device duty for 1-phase panel / UPS systems
- Unbalanced L-G, L-L, & L-L-G faults analysis
- Transient IEC 61363 short circuit calculations
- Compares device ratings with calculated short circuit values
- User-definable voltage C factor
- Service or ultimate short circuit current ratings for LVCB breaking capability
- User-definable R/X adjustment methods for I_p (method A, B, or C)
- Phase-shifting transformers
- Negative or positive impedance adjustments for max/min I''_k & I_k
- Automatic application of K correction factors (i.e., KT, KG, KSO)
- Automatically determines meshed & non-meshed networks for calculating I_b , I_k , & I_{dc}
- I_b for meshed network is adjusted by individual machine contributions for improved accuracy
- Considers both near & far from generator short circuits
- Generates relay test set compatible plots for transient short circuits
- Detailed IEC device duty reports & complete contributions for unbalanced faults

Standards

- IEC 62271-100 High-Voltage Switchgear and Controlgear, Part 100: High-Voltage Alternating-Current Circuit Breakers
- IEC 62271-200 High-Voltage Switchgear and Controlgear, Part 200: AC Metal-Enclosed Switchgear and Controlgear for Rated Voltages Above 1 kV and up to and including 52 kV
- IEC 62271-203 High-Voltage Switchgear and Controlgear, Part 203: Gas-Insulated Metal-Enclosed Switchgear for Rated Voltages Above 52 kV
- IEC 60282-2 High-Voltage Fuses, Part 2: Expulsion Fuses
- IEC 60909-0 Short Circuit Currents in Three-Phase AC Systems, Part 0: Calculation of Currents (including 2002 Corrigendum 1)
- IEC 60909-1 Short Circuit Currents in Three-Phase AC Systems, Part 1: Factors for the Calculation of Short Circuit Currents According to IEC 60909-0
- IEC 60909-2 Electrical Equipment – Data for Short Circuit Current Calculations in Accordance with IEC 909 (1988)
- IEC 60909-4 Short Circuit Currents in Three-Phase AC Systems, Part 4: Examples for the Calculation of Short Circuit Currents
- IEC 60947-1 Low Voltage Switchgear and Controlgear, Part 1: General Rules
- IEC 60947-2 Low Voltage Switchgear and Controlgear, Part 2: Circuit Breakers
- IEC 61363-1 Electrical Installations of Ships and Mobile and Fixed Offshore Units, Part 1: Procedures for Calculating Short Circuit Currents in Three-Phase AC

