

Panel Systems

Ultimate Tool for Panel Systems Design and Analysis

Developed for electrical designers and engineers, the Panel Systems module combines a graphical user interface and the intelligence of ETAP to easily design and analyze low voltage distribution systems. Coupled with exclusive features and advanced capabilities, Panel Systems is a quality tool you would only expect from the leader in power system analysis software.

Intelligent Design with an Integrated Layout

Key Features

- Panel Design & Analysis
- 1-Phase & 3-Phase
- ANSI & IEC Standards
- NEC® Load Factors
- Intelligent Panel Calculations
- Automatic Update of Upstream Panels

Capabilities

- NEC • ANSI • IEC Standards
- 3-Phase 3 Wire • 3-Phase 4 Wire
- 1-Phase 2 Wire • 1-Phase 3 Wire
- Column & standard layouts
- Unlimited branch circuits
- Unlimited sub-panel connections
- External network representation
- Internal (spreadsheet) load modeling
- Intelligent panel calculations
- Detailed panel loading summary
- Dynamic panel schedule updates
- Continuous & non-continuous load calculations



Flexible Operation

- Diverse operating conditions
- Multiple loading categories
- Multiple demand factors
- Unlimited configurations
- Different nameplate data
- Global & individual bus load diversity factors

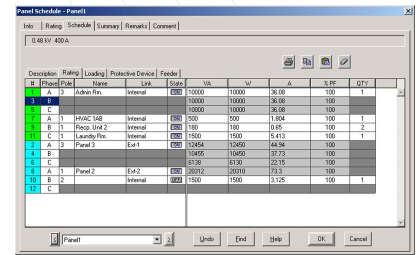

Study Options

- Ten loading categories per circuit
- User-definable load types & factors

Libraries

- Extensive protection & control device libraries
- Comprehensive feeder & cable libraries
- Customizable libraries
- User-configurable defaults & layouts

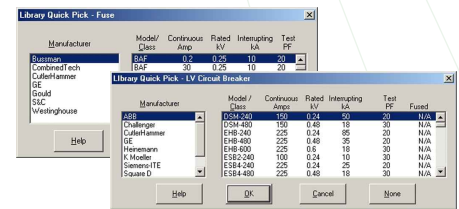

Panel Code Factors

- NEC load demand factors
- Customizable multiplying factors

Reporting

- Customizable panel schedules in Crystal Reports® format
- Comprehensive load summary for panel sizing
- Customizable reports for branch circuit evaluation
- Export one-line diagrams with results to third party CAD systems

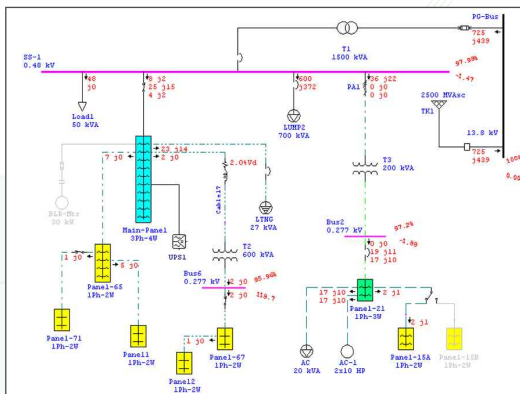

Detailed Low Voltage Distribution

Panel ID:		Panel1													
Voltage:	480 Volts	Panel Layout:	Standard	Feed:	Bottom										
Rating:	400 Amps	No. of Circuits:	12	Enclosure:	NEMA 1										
	3 Phase, 4 Wire	Connected Bus:	MCCI1	Mounting:	Flush										
Load Name	Watts			FDR Size	Pole	CB Amp	Ckt#	Ckt#	CB Amp	Pole	FDR Size	Watts			Load Name
	A	B	C									A	B	C	
Adv In Rm.	10000			6	3	20	1	2	20	3	12450				Panel3
		10000					3	4				10450			
			10000				5	6					6130		
HVAC LAB	500			12	1	15	7	8	25	1	20310				Panel2
Recp. Rm. 2	180			12	1	15	9	10	20	2	1500				
Laundry Rm.			1500	14	1	15	11	12	15	8					
Total Watts	A:	B:	C:	Total Continuous Watts	A:	B:	C:	Total Non-Continuous Watts	A:	B:	C:	Total Watts	A:	B:	C:
	43260	21560	18380		36760	20810	17650		6500	750	750				

- Unlimited Panels & Sub-Panels
- No Voltage Limitations
- Multiple Isolated Sub-Systems
- Customizable Libraries
- Graphical Display of Results on One-Line Diagrams
- Customizable Font Types, Sizes, Styles, & Colors
- Customizable Display of Ratings & Results
- Automatic Error Checking
- Graphical Display of Overstressed Devices
- Dynamically Adjust Display of Results

