

# *Battery Sizing & Discharge*

## **Selective Efficient Powerful**

Battery Sizing and Discharge Analysis is used to select the most appropriate battery banks, verify the maximum capability of existing batteries, and easily simulate a wide range of backup, control, and other DC scenarios. Multiple duty cycles for various equipments are compiled along with randomly activated DC loads to simulate situations such as shutdowns and emergency conditions. Multiple corrective factors are used to compensate for real-life variables such as temperature, aging, and initial capacity that apply to these types of critical electrical systems.

# Simulate Real Operating Conditions

battery sizing & discharge

## Key Features

- Battery Sizing
- Battery Discharge Simulation
- Load Diversity Factor
- Voltage Drop & Loss Consideration
- Class 1E DC Power & Control System Models

## Plots

- Battery voltage, Amp, & AH
- Battery duty cycle (random & non-random loads)
- Battery characteristic curves
- Branch current & power flow
- Bus voltage & loading
- Zoom to any detail level
- Export data to Microsoft® Excel
- Line, Bar, 3-D, & scatter plots
- Change text & axes

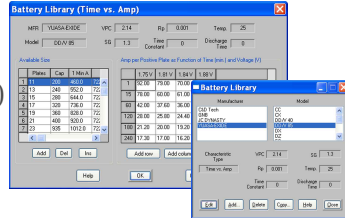

## Capabilities

- Battery sizing based on IEEE Standards 308, 485, & 946
- Battery sizing based on:
  - Load flow method (includes losses & voltage drops)
  - Duty cycle summation method
- Battery correction factors for:
  - Temperature
  - Aging
  - Initial capacity
  - Design margin
- Automatic battery size verification by battery discharge simulation
- Battery discharge simulation based on:
  - Load flow method (includes losses & voltage drops)
  - Duty cycle summation method
- Automatic addition of random load at the lowest battery terminal voltage
- Multiple load duty cycles for simulating different practical scenarios
- Load duty cycle adjustment based on load diversity & battery correction factors
- Unlimited number of system configurations to easily simulate different emergency conditions

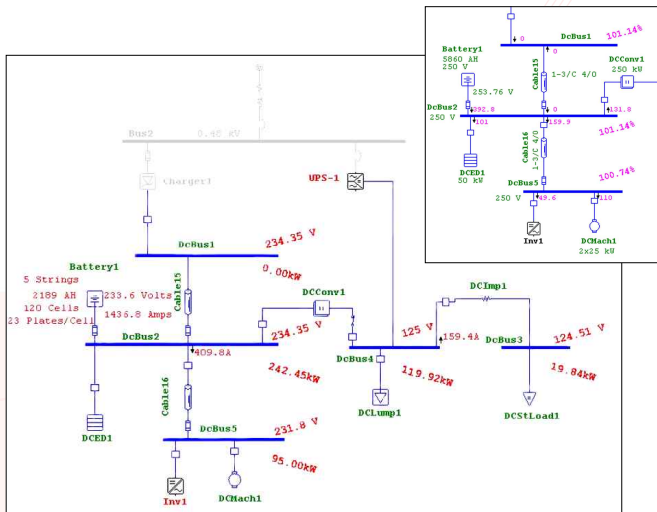

## Reporting

- Battery & load duty cycle
- Battery characteristics
- IEEE 485 format
- Tabulate simulation results
- Export one-line diagrams with results to third party CAD systems
- Use Crystal Reports® for full color, customizable reports

## Advanced Battery Selection & Verification

- Unlimited Buses\* & Elements
- No Voltage Limitations
- Looped & Radial Systems
- Integrated 1-Phase, 3-Phase, & DC Systems
- Multiple Generators & Grid Connections
- Multiple Isolated Sub-Systems
- Customizable Libraries
- Graphical Display of Results on One-Line Diagrams
- Customizable Font Types, Sizes, Styles, & Colors
- Customizable Display of Ratings & Results
- Graphical Display of Equipment Impedance & Grounding
- Automatic Error Checking
- Graphical Display of Overstressed Devices
- Graphical Display of Over/Under Voltage Buses
- Dynamically Adjust Display of Results

\*Maximum number of energized buses during calculations is license dependent.

| Non-Random Loads<br>(5 Strings)   |                |                          |                              |                                  |  |  |
|---|----------------|--------------------------|------------------------------|----------------------------------|--|--|
| Period  | Load (amperes) | Change-in Load (amperes) | Duration of Period (minutes) | Time to End of Section (minutes) | Capacity at T Min Rate (kWh) (Str * Amp * T) | Required Section Size (Effective Plates) |
| Section 1 - First period only - If A1 is greater than A1, go to Section 2.        |                |                          |                              |                                  |  |  |
| 1   | A1=994         | A1=0-994                 | M1=1                         | T=M1=1                           | 754.3  | 6.59                                     |
| Section 1 Sub-Total:  |                |                          |                              |                                  | 1.32   | 6.59                                     |
| Total:  |                |                          |                              |                                  | 1.32   | 6.59                                     |
| Section 2 - First two periods only - If A3 is greater than A2, go to Section 3.   |                |                          |                              |                                  |  |  |
| 1   | A1=994         | A1=0-994                 | M1=1                         | T=M1=2                           | 1508.6                                       | 13.18                                    |
| 2   | A2=774         | A2=A1-220                | M2=2                         | T=M2=2                           | 1508.6                                       | 13.18                                    |
| Section 2 Sub-Total:  |                |                          |                              |                                  | 3.02   | 26.36                                    |
| Total:  |                |                          |                              |                                  | 4.34   | 32.95                                    |
| Section 3 - First three periods only - If A4 is greater than A3, go to Section 4. |                |                          |                              |                                  |  |  |
| 1   | A1=994         | A1=0-994                 | M1=1                         | T=M1=M2=M3=60                    | 3510.6                                       | 30.44                                    |
| 2   | A2=774         | A2=A1-220                | M2=2                         | T=M2=M3=60                       | 3510.6                                       | 30.44                                    |
| 3   | A3=1057        | A3=A2+283                | M3=30                        | T=M3=30                          | 5162.2                                       | 44.77                                    |
| Section 3 Sub-Total:  |                |                          |                              |                                  | 12.18  | 105.65                                   |
| Total:  |                |                          |                              |                                  | 15.50  | 138.60                                   |
| Section 4 - First four periods only - If A5 is greater than A4, go to Section 5.  |                |                          |                              |                                  |  |  |
| 1   | A1=994         | A1=0-994                 | M1=1                         | T=M1=1                           | 754.3  | 6.59                                     |
| 2   | A2=774         | A2=A1-220                | M2=2                         | T=M2=M3=M4=119                   | 2304.4                                       | 19.85                                    |
| 3   | A3=1057        | A3=A2+283                | M3=30                        | T=M3=M4=90                       | 2760.6                                       | 23.74                                    |
| 4   | A4=977         | A4=A3-80                 | M4=60                        | T=M4=60                          | 3510.6                                       | 30.44                                    |
| Section 4 Sub-Total:  |                |                          |                              |                                  | 5.36   | 46.62                                    |
| Total:  |                |                          |                              |                                  | 20.86  | 185.27                                   |
| Section 5 - First five periods only - If A6 is greater than A5, go to Section 6.  |                |                          |                              |                                  |  |  |
| 1   | A1=994         | A1=0-994                 | M1=1                         | T=M1=1                           | 754.3  | 6.59                                     |
| 2   | A2=774         | A2=A1-220                | M2=2                         | T=M2=1                           | 1508.6                                       | 13.18                                    |
| 3   | A3=1057        | A3=A2+283                | M3=30                        | T=M3=M4=M5=5                     | 1508.6                                       | 13.18                                    |
| 4   | A4=977         | A4=A3-80                 | M4=60                        | T=M4=M5=5                        | 1508.6                                       | 13.18                                    |
| 5   | A5=994         | A5=A4+17                 | M5=30                        | T=M5=5                           | 1508.6                                       | 13.18                                    |
| Section 5 Sub-Total:  |                |                          |                              |                                  | 5.36   | 46.62                                    |
| Total:  |                |                          |                              |                                  | 26.22  | 231.89                                   |

