



**Visualize**  
**Analyze**  
**Optimize**

ETAP Distribution Management System is an integrated electrical system design and real-time power distribution management system. ETAP DMS provides the necessary mission critical applications to efficiently, reliably and securely manage, control, visualize and optimize distribution networks.

- Geospatial Transmission & Distribution Views
- Real-Time Distribution Network Applications
- Network Topology Builder & Processor
- State Estimation & Load Distribution
- Power System Monitoring & Control
- Intelligent Demand Management & Load Shedding
- Switching Sequence / Work Order Management
- Fault Management & Service Restoration
- Automatic Voltage / Var Optimization & Control
- Loss Minimization & Load Balancing
- Switching Optimization
- Geographic Information System Interface
- Redundant Fault Tolerant Software Architecture

# ***Distribution Management System***

## ***DMS***

# Distribution Management System

ETAP offers a suite of fully integrated electrical engineering software solutions that integrates a graphical user-friendly power system design & modeling platform with advanced suite of real-time power distribution applications. ETAP Distribution Network Applications are modular and include intelligent power monitoring, real-time predictive simulation, distribution management, and system optimization.

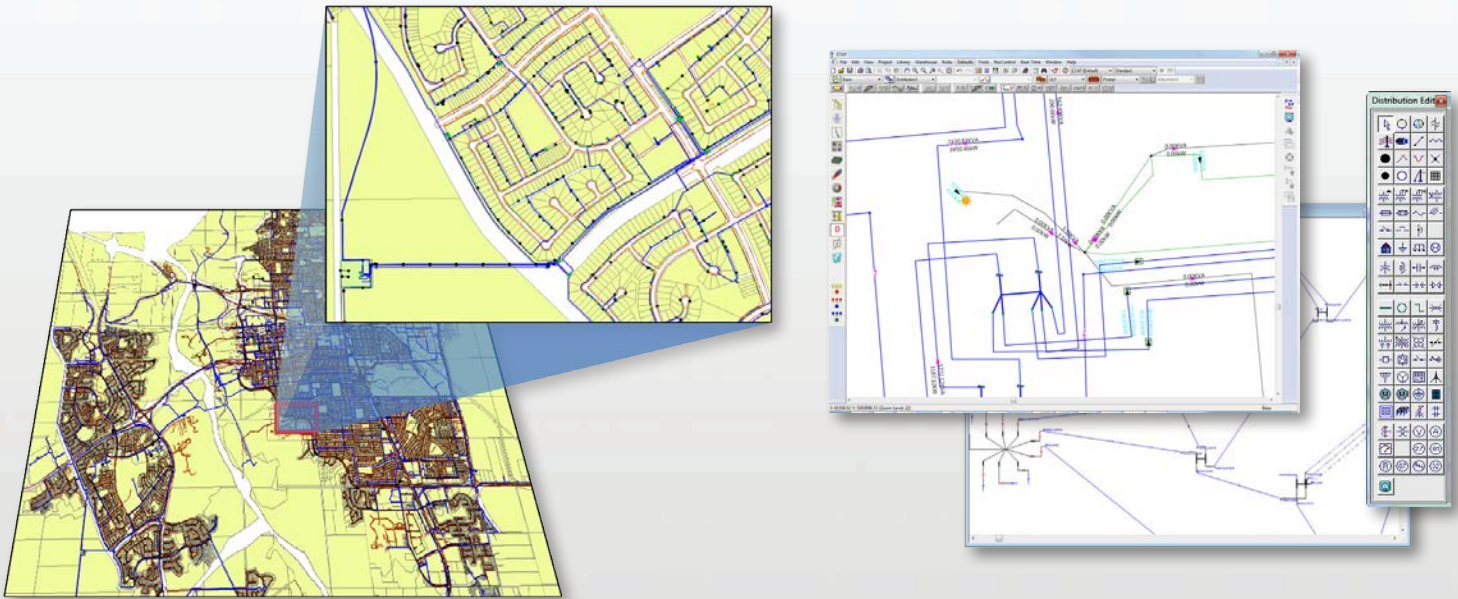

*Visualize & Analyze Distribution Systems  
Using Geospatial & Logical Views*

## Distribution Network Applications

- State Estimation & Load Distribution
- Predictive Simulation
- Event Playback
- Unbalanced Load Flow
- Short-Circuit
- Device Coordination & Selectivity
- Sequence-of-Operation
- Arc Flash
- Power Quality & Harmonics
- Underground Cable Thermal Analysis
- Reliability Assessment
- Failure Mode & Effects Analysis
- Switching Sequence Management
- Switching Optimization
- Contingency Analysis
- Fault Management & Service Restoration
- Voltage / Var Optimization & Control
- Transformer Load Management
- Distributed Generation Modeling & Simulation

## Features

- Intelligent Geospatial Electrical Views
- Full spectrum AC & DC analysis
- Intelligent equivalent one-line diagrams
- Emulate response of protective devices
- Evaluate protection & control actions
- Get online data on-demand
- Retrieve archived data for system analysis
- One-touch simulation
- View & analyze initial & post-disturbance actions
- Intelligent interactive graphical user interface
- Online simulation alerts
- Electrical & physical geospatial objects
- Automatic scenario simulation using Project Wizard
- Detailed Layer & Color Management
- Multi-dimensional database
- Integrated alarm, warning, & acknowledgement
- Client-server configuration
- Built-in redundancy & automatic fail over
- Thin client dashboards

## Network Topology Builder & Processor

Network Topology Builder is a user-friendly environment for creating and managing the network database. It is used for geo-spatial network visualization and is the foundation of real-time applications. It allows for direct import of electrical data from a GIS database and dynamically creates equivalent feeders / reduced networks while maintaining a complete geospatial view of the distribution system.

## Advanced Monitoring with State Estimation

Advanced Monitoring provides intuitive, intelligent, and integrated real-time monitoring via a state-of-the-art interface. ETAP's open architecture structure allows seamless integration with metering devices, data acquisition, and archiving systems, which is an essential capability for distribution management system.

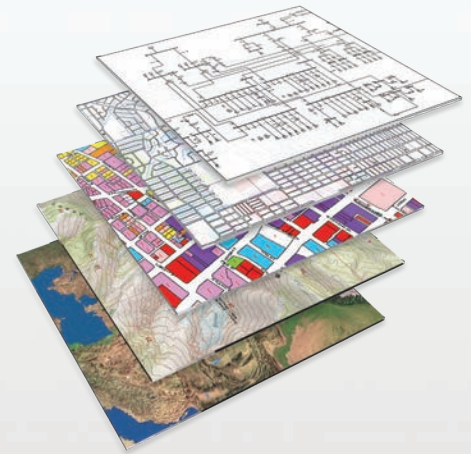

## Predictive Simulation

Predictive Simulation is a powerful set of analytical modules that allows the prediction of system behavior in response to operator actions and events using real-time and archived data.

## Event Playback

Event Playback is especially useful for root cause and effect investigations, improvement of system operations, exploration of alternative actions, and replay of "What If" scenarios. ETAP can be configured to provide a complete picture of the electrical system from stored data accessed from Information Storage & Retrieval (ISR) system. This includes playback of previously recorded monitored data, calculated system parameters, sequence of events, and message log.

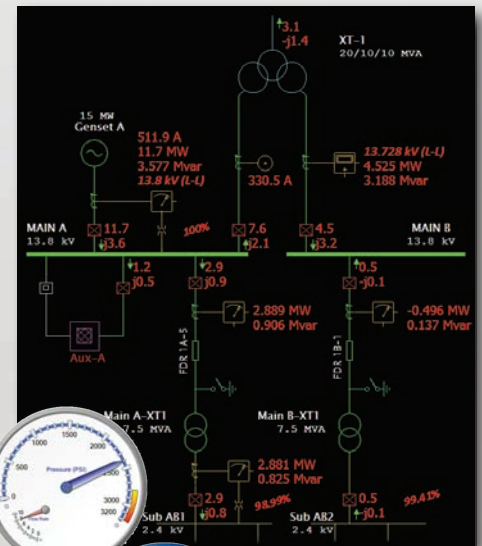

## Dispatcher Training Simulator

Dispatcher Training Simulator is a set of analytical modules that allows prediction of system behavior in response to operator actions using configurable scenarios. Compared to traditional training methods, operator training is accelerated using dynamic graphical simulation of the power system. This makes training an ongoing process.

## Switching Optimization

Switching Optimization is a tool to automatically determine the optimal system configuration to achieve a single or multiple user-specified objectives. It provides optimal status of existing switching devices and suggests locations for new tie open points in the system.

## Switching Management

Switching Sequence/ Work Order Management allows the dispatcher to build, simulate, and verify a complete switching program using a fully graphical user interface and execute the approved switching programs in one step while maintaining compliance with safety and security procedures.

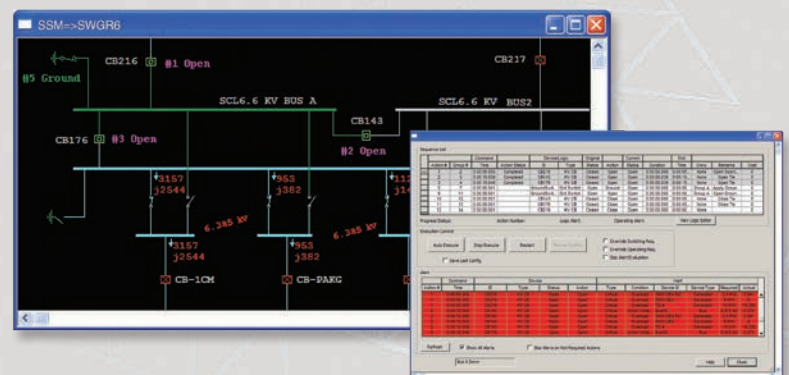

## Short-Term Load Forecasting

Load Forecasting reliably predicts and trends system loading based on algorithms that adaptively correlate multiple input variables such as weather conditions as part of an accurate load forecast.

## Transformer Load Management

Transformer Load Management estimates load profile of transformers based on the derived monthly kWh data for each customer.

## Intelligent Load Management

Demand Management identifies costly variations in electrical load profiles by determining if and when peak demand usage occurs on a feeder basis. Since demand can often vary hourly, daily, or monthly, specific power purchase surcharges can be reduced or eliminated by pinpointing the source and length of the peak demand usage.

## Intelligent Load Shedding

Intelligent Load Shedding (ILS) provides optimal, fast load shedding for electrical disturbances and loss of generation. ILS calculates the minimum required MW to be shed for each subsystem according to the type and location of the disturbance, actual operating generation, spin reserve, loading, configuration, load distribution, and priority. ILS then selects the best combination of loads (CBs) that will satisfy this requirement. All of this is executed in less than a few milliseconds after a disturbance occurs in the system.

## Fault Management & Service Restoration

Service Restoration application minimizes the duration of an outage following a disturbance by automatically restoring power to the available portions of the system without exceeding the capacities of alternate power sources and routes.

## Volt / Var Optimization

Volt / Var Optimization utilizes intelligent optimal power flow to automatically adjust the power system control settings while simultaneously solving the load flows and optimizing operating conditions within specific constraints.

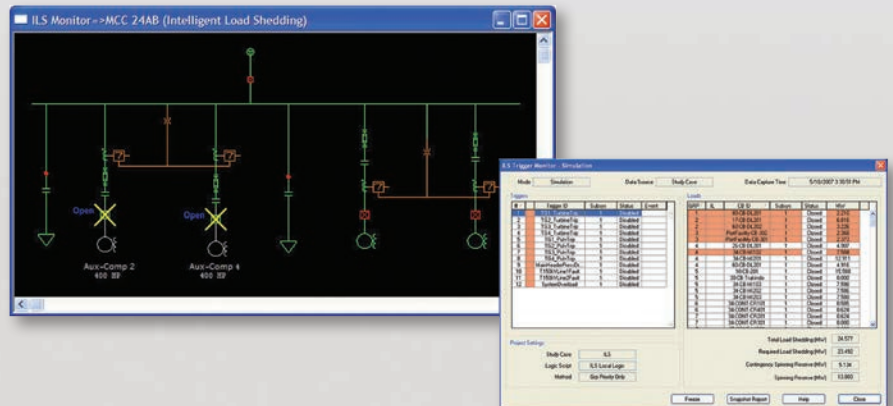
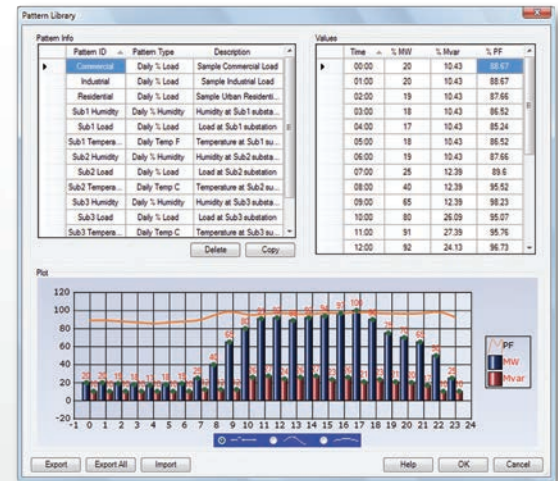

**etap.com**

T 800.477.ETAP  
T 949.900.1000

